

VALPES

VALVE CONTROL SYSTEM

ELEMENTS DE REGULATION ET DE CONTROLE
ELEMENTS OF REGULATION AND CONTROL

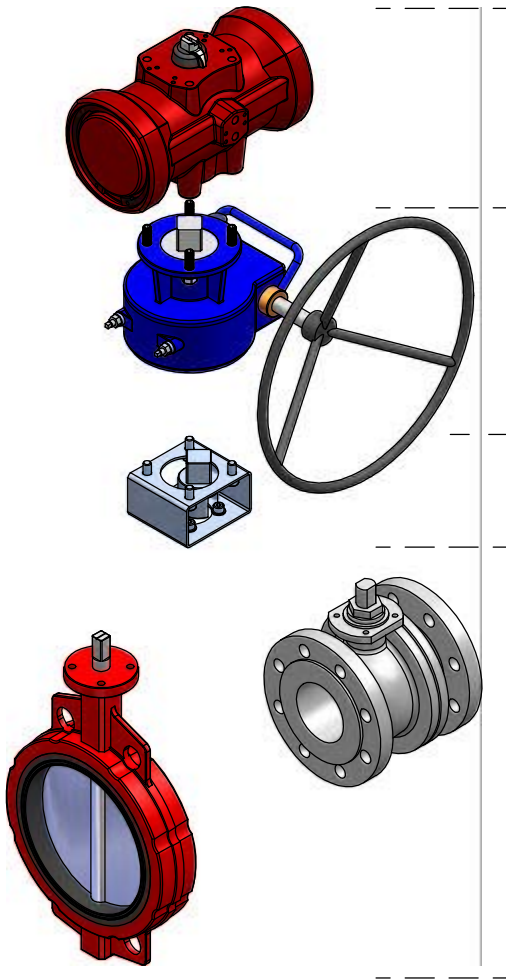

1 ACTIONNEUR PNEUMATIQUE
PNEUMATIC ACTUATOR

2 REDUCTEUR DEBRAYABLE
CLUTCH GEARBOX

3 KIT DE MONTAGE POUR VANNE
VALVE COUPLING

4 VANNE A BILLE OU PAPILLON
BALL OR BUTTERFLY VALVE



REDUCTEUR DEBRAYABLE
CLUTCH GEARBOX

DEBRAYAGE PAR LEVIER
CLUTCHING BAR LEVER

SYSTEME DE BLOCCAGE
SYSTEM LOCK AND BLOCK

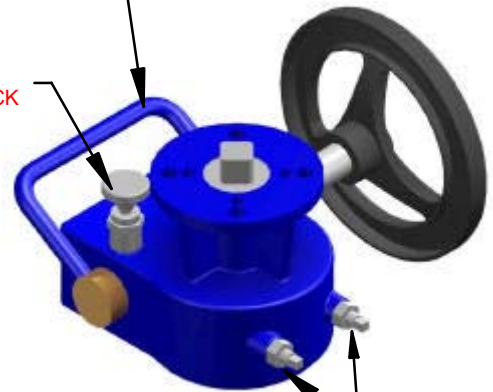

BUTEES DE REGLAGE
REGULATION BUTTS

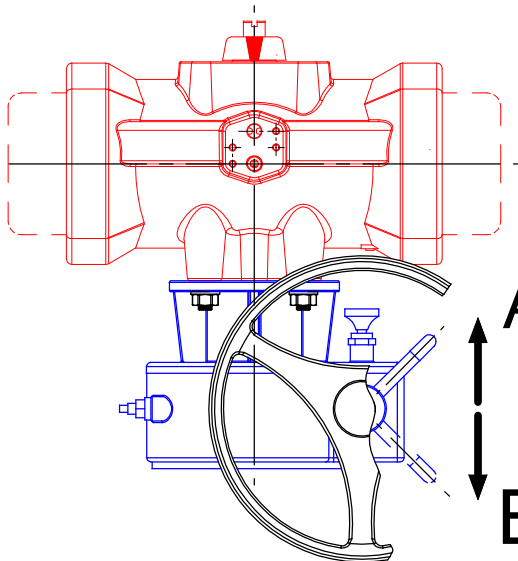

A REDUCTEUR DEBRAYE
UNCLUTCHED GEARBOX

B REDUCTEUR EMBRAYE
CLUTCHED GEARBOX

REMARQUE: NE PAS MONTER AVEC DES ACTIONNEURS 180°
REMARK: NOT APPLICABLE TO 180° ACTUATORS

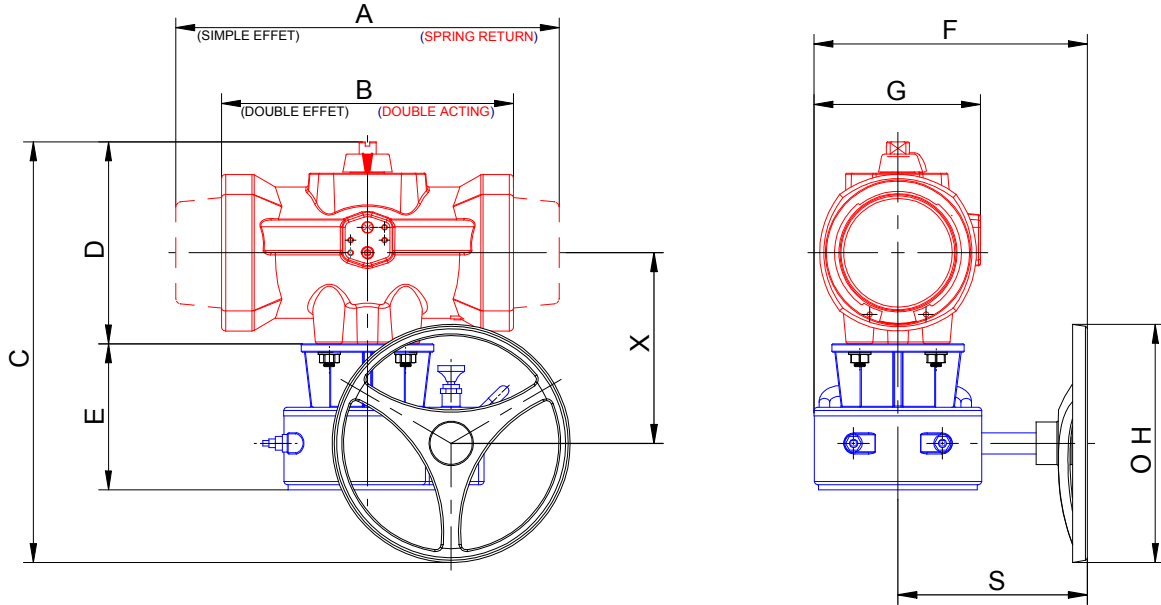

DIMENSIONS ACTIONNEUR + REDUCTEUR
DIMENSIONS ACTUATOR + GEARBOX

ACTIONNEUR ACTUATOR	REDUCTEUR GEARBOX	DIMENSIONS (mm)											
		A	B	C	D	E	F	G	S	H	X		
P00-P00S	PMG.00	158	125	254	110			105			119		
P05-P05S	PMG.10	194	146	267	122	105	221	114	160	140	122		
P10-P10S		230	178	271	127			116			124		
P15-15S		256	204	292	148			121			137		
P20-20S		PMG.20	308	234	368			164			122	243	140
P25-P25S	PMG.30	365	276	460	191	138	258	166	170	350	180		
P30-P30S		470	308	479	210						261	185	190
P40-P40S		PMG.40	642	418	618						275	163	366
P50-P50S	PMG.50	694	524	738	306	195	554	308	381	600	265		

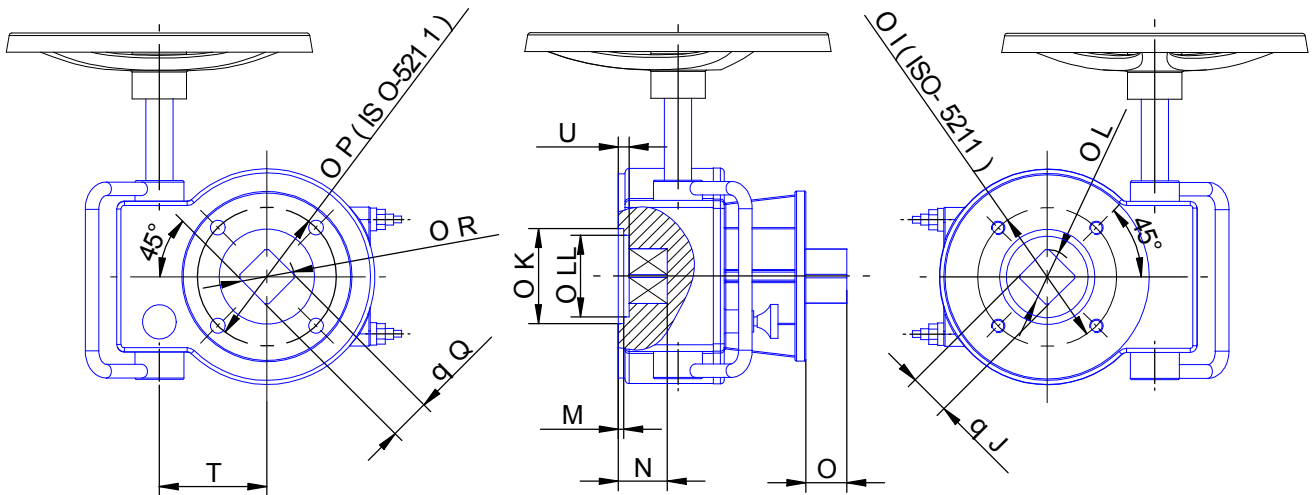

DIMENSIONS REDUCTEUR
GEARBOX DIMENSIONS

ACTIONNEUR GEARBOX	COTE VANNE									COTE ACTIONNEUR					POIDS WEIGHTS	
	ISO-5211	I	J	L	U	K	LL	M	N min.	O max.	ISO-5211	P	Q	R		T
PMG.00 PMG.10	F05-F07	50-70	17	22,5	6,5	35	29,8	3	16	14	F05-F07	50-70	17	21,5	45	4,4 Kg
PMG.20	F07	70	19	25,5	5	55	38	4	20	19	F07	70	19	24,5	50	7,4 Kg
PMG.30	F10	102	30	40	8	70	60	4	32	30	F10	102	30	39,8	79	12 Kg
PMG.40	F12	125	36	49	-	85	-	6	40	38	F12	125	36	48,8	90	22,6 Kg
PMG.50	F14	140	36	49	-	100	-	6	40	38	F14	140	36	48,8	141	52,3 Kg

DIMENSIONS EN (mm)
DIMENSIONS IN (mm)